

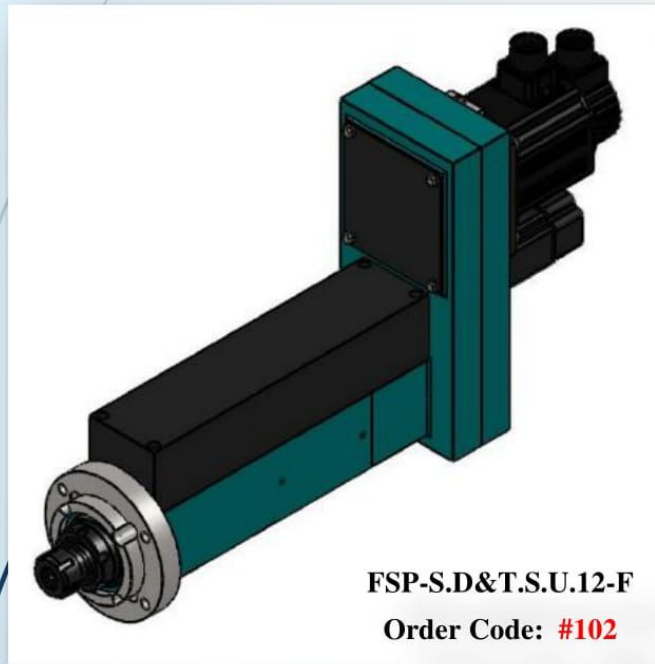

Servo Drilling & Tapping Spindle Unit Flange Type.12



Technical Data	
Total Stroke	80 mm
Adjustable Stroke	80 mm
Tapping Capacity	M 12
Spindle Nose	ER 25
Max RPM	3000 RPM
Timing Belt Type (Tapping Spindle Unit)	5 M
Timing Belt Type (Drilling Spindle Unit)	RB-PJ
Chrome Plated Quill, Guided In Honed Housing	0.05 clearance
Servo Motor Spindle	1 kw
Servo Motor Feed	400/700 w
Ball Screw And Nut	HIWIN- 16 - 05
Bearing Arrangement	(2×32004) + (2×6007) or (2×6004) + (2×6007)
Weight	50 kg
Color	



