

Hydraulic Two Jaws. 130

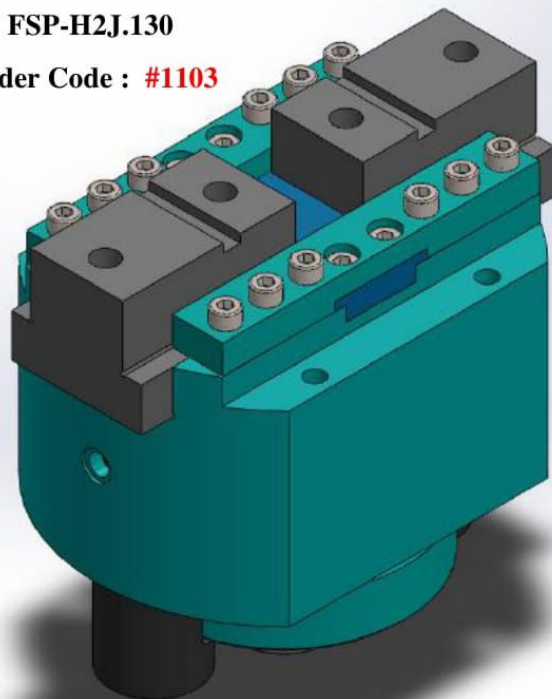

FSP-H2J.130

Order Code : **#1103**



Technical Data

Total Stroke	50 mm
Working Pressure	Max 60 bar
Hydraulic Seals	Kastas
Body Material	41 CrMo4
Theoretical Clamping Force At 40 Bar	1100 daN
Reproducibility	± 0.01
Working Temperature	70 – 80 °C



